

eBOOK

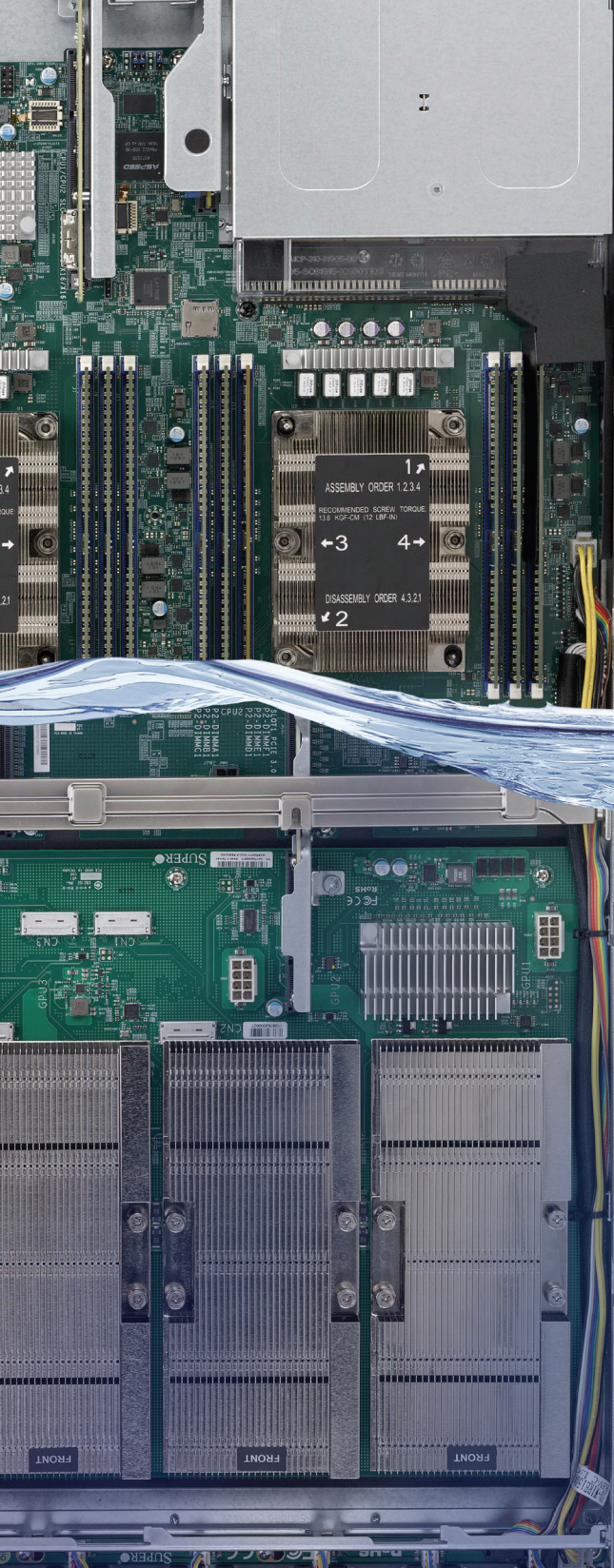

The
**Definitive
Guide to**



**Immersion
Cooling**

Reduce Costs. Scale Easily.
Enhance Sustainability.



Reasons to Read This Book

- ➔ Large CapEx and/or increased OpEx are causing you to look to the cloud or colocation.
- ➔ You're looking for more sustainable/greener data center solutions?
- ➔ Your data center is running out of power and will be unable to handle your increasing capacity.
- ➔ ITE refreshes are more complex and expensive than necessary due the cost of associated cooling infrastructure updates.
- ➔ Your data center is running out of space to add necessary compute.

Table of Contents

Data Center Infrastructure Barriers	2-3
About Conventional Cooling	4
Data Center Cooling Through the Decades	5-8
Not All Liquid Cooling Solutions Are Similar	9
Introducing Immersion Cooling	10
Why Immersion Is Superior to Air	11
Two-Phase vs. Single-Phase Immersion Cooling.....	12-13
What Single-Phase Immersion Cooling Can Do for You.....	14-18
Solutions to Data Center Challenges.....	19
Here's What You Learned.....	20
Future-Proofing Your Data Center.....	21

Data Center Demands Are **Rising**

“It’s Getting **Hot** in Here”

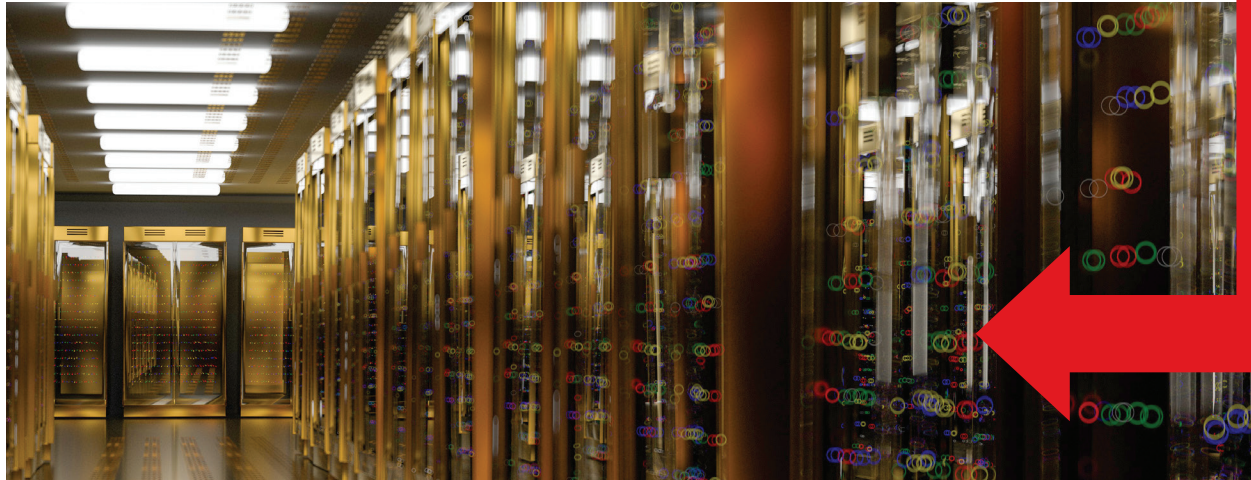

More and more, data has become the lifeblood of human commerce. What’s more, the simple, inexorable growth in heat generated by technology is pushing legacy, air-cooling infrastructure beyond its limits. As a result, companies are realizing the importance of undergoing a digital transformation to accomplish their mission.

Next-gen applications like artificial intelligence (AI), the Internet of things (IoT and IIoT), augmented reality (AR), and machine learning (ML) are becoming critical tools and requiring ever-denser, more complex CPUs.

Edge computing is demanding the fast deployment of resources in remote and often brutal environments.

Newer, faster GPUs are driving today’s graphics-intensive workloads.

With all those electrons racing around, data centers have become the heart of many organizations. But they’ve also become a focus of concern as high-density technology trends generate unprecedented amounts of heat and push hardware to the limit, and there are no signs of slowing down.

IT leaders are searching for answers.



Cold Hard Fact:

Infrastructure Is **Getting in the Way**

It's increasingly clear that, relying strictly on conventional data center infrastructure, IT professionals cannot rise to meet today's challenges with any degree of energy-efficiency.

Augmenting with similar infrastructure can make operational costs soar. Conventional construction lead times are long, and capacity planning is difficult given current trendlines. Plus, operators are realizing they'll run out of power and space before achieving the required density.

Meanwhile, data centers continue heating up.

Operators will struggle to meet tomorrow's data center cooling and capacity challenges with conventional data center infrastructure.



Status Quo Won't Cut it (or Cool It) Anymore

Legacy systems could be stretched to meet some of the density and heat-related challenges data centers face today. But, at some point, using old technology to solve new problems stops making sense.

To breathe easier — and sleep better at night, infrastructure and operations (I & O) professionals need a breakthrough. And they need to react now.

This guide will help.

How? By introducing a field-proven, cost-effective, highly-scalable, and quickly-deployable solution known as single-phase immersion cooling.

Conventional Cooling,

Your Time is Up

Since the 1920s, mechanical air conditioning has been the preferred way to cool buildings. So, for the longest time, conventional wisdom held that A/C was the best way to cool a data center, too.

But times have changed — data centers got hotter, and air's limitations became clearer.



The fact is, air is a poor transfer agent of heat.

While data center chillers and handlers worked fine when hardware densities were low, and efficiency wasn't an issue, their efficacy waned as densities rose. Soon, data centers started employing fluid coolants because they have a significantly higher heat capacity than air by volume.

Finally — and largely out of necessity, we arrived at liquid immersion cooling.

Data Center Cooling

Through the Decades

Over the past quarter-century and longer, data center cooling has evolved from simplistic systems scarcely more sophisticated than residential A/C to more complex technologies involving fluid coolants. As densities increased, those coolants moved ever-closer to the heat source.

Let's start off with some context, Power Usage Effectiveness, or PUE, is the ratio of energy use within a facility compared to ITE energy use. It measures the effectiveness of cooling systems. The perfect PUE, especially if describing a perfect scenario, would be 1.0. That means that all the power coming into the facility is used by the ITE inside. Below shows the progress from the '70s to present day.

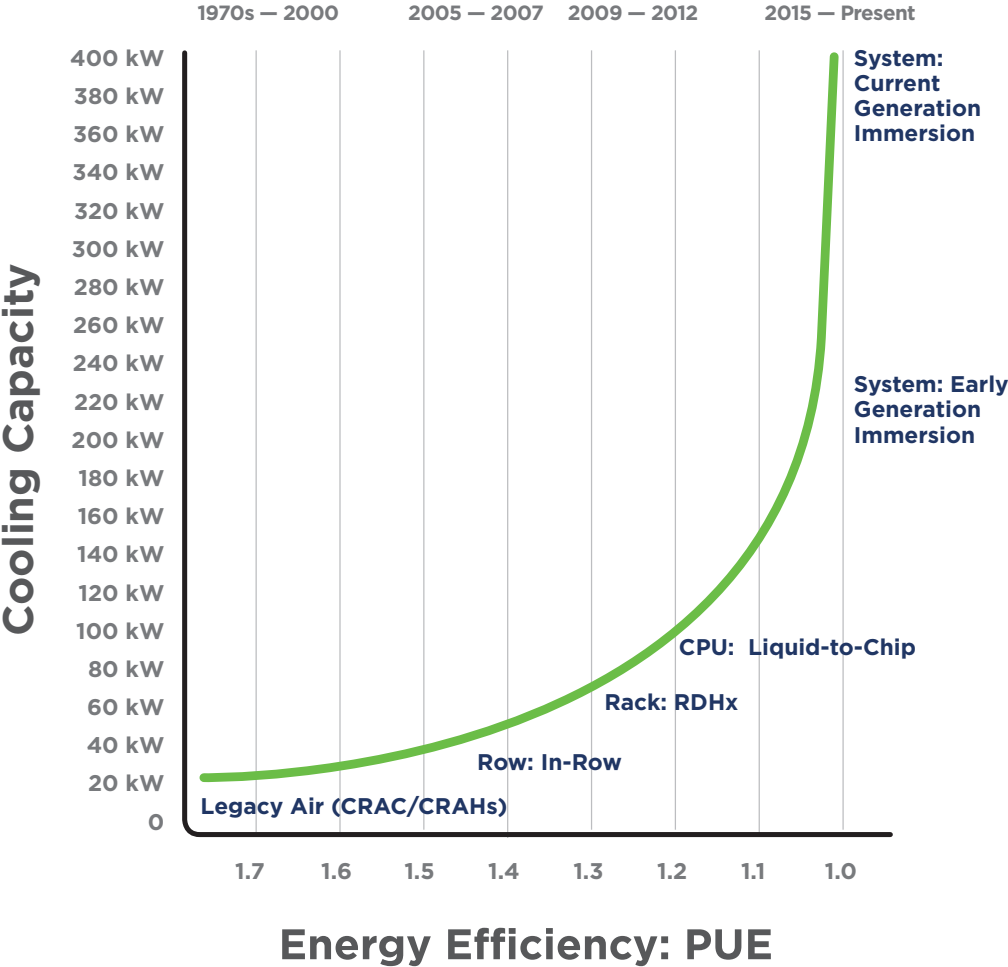

Data Center Cooling

Through the Decades (continued)

Legacy Air-Cooling (CRACs/CRAHs)

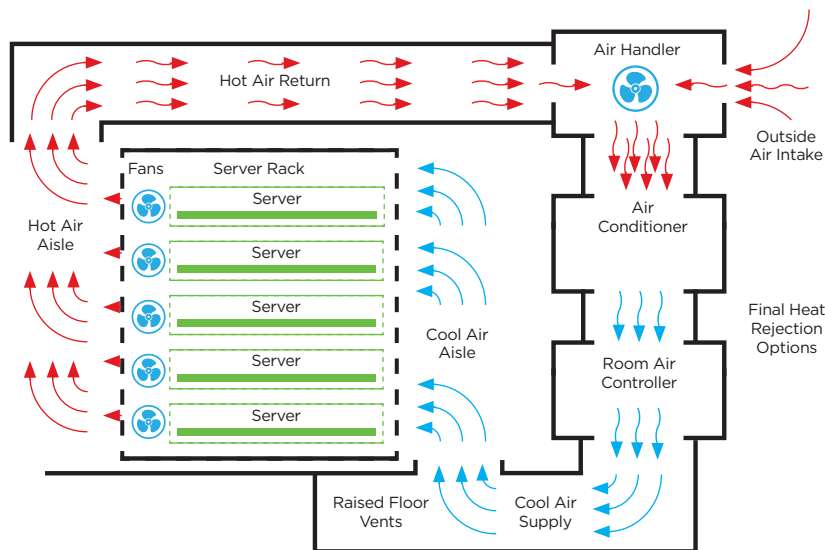

Legacy Air-Cooling Up to 15 kW/Rack

Cools the entire computer room using room air conditioners and handlers.

In-Row Air-Cooling

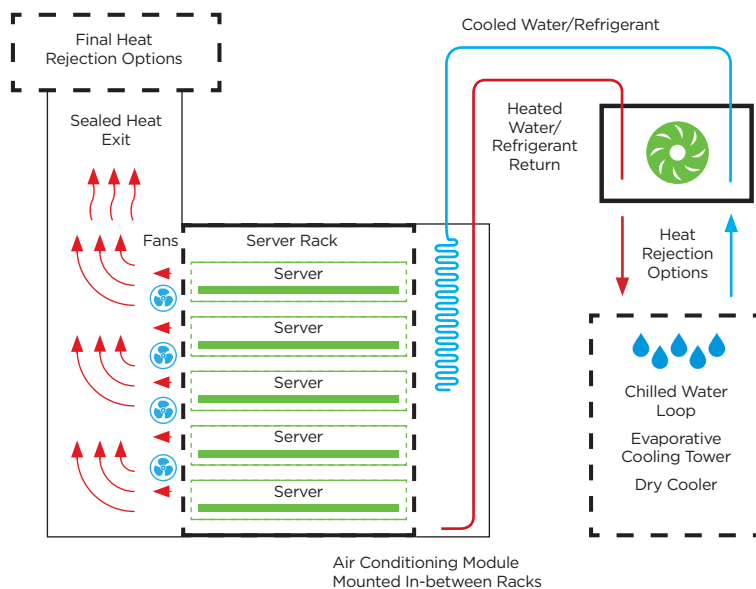

In-Row Cooling Up to 25 kW/Rack

More precisely cools and conditions air in close proximity to servers, and uses aisle containment.

Data Center Cooling

Through the Decades (continued)



Rear Door Heat Exchanger Cooling (RDHx)

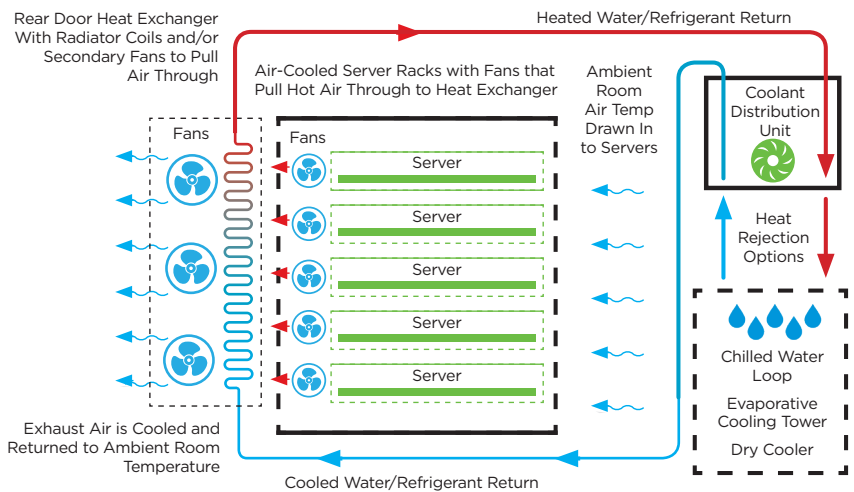

Rear-Door Heat Exchangers Up to 55 kW/Rack

RDHx bring the cooling effects of a liquid-to-gas phase change closer to the heat source.

Liquid-to-Chip

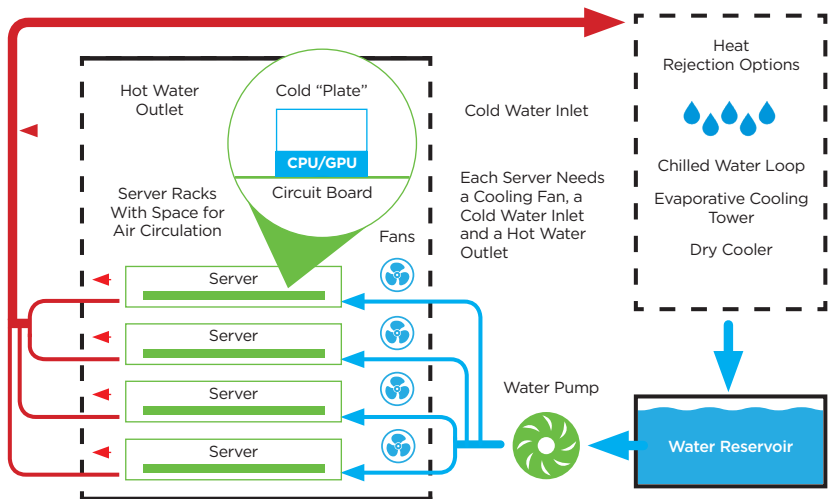

Liquid-to-Chip Up to 75 kW/Rack

Liquid-cooled heat sinks are attached externally to a metal plate atop CPUs.

Data Center Cooling

Through the Decades (continued)

Single-Phase Immersion Cooling

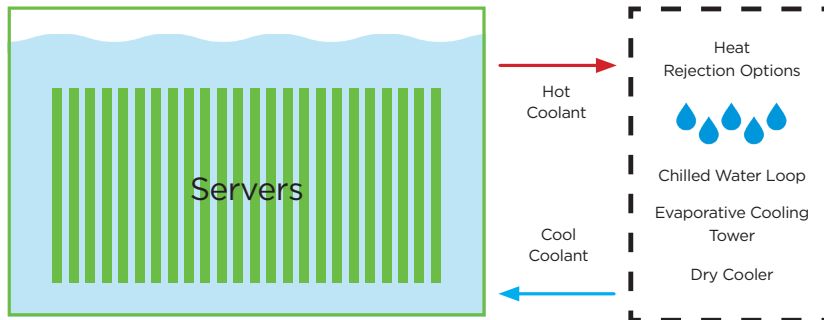

Horizontal Rack With Servers Completely Immersed in Dielectric Coolant

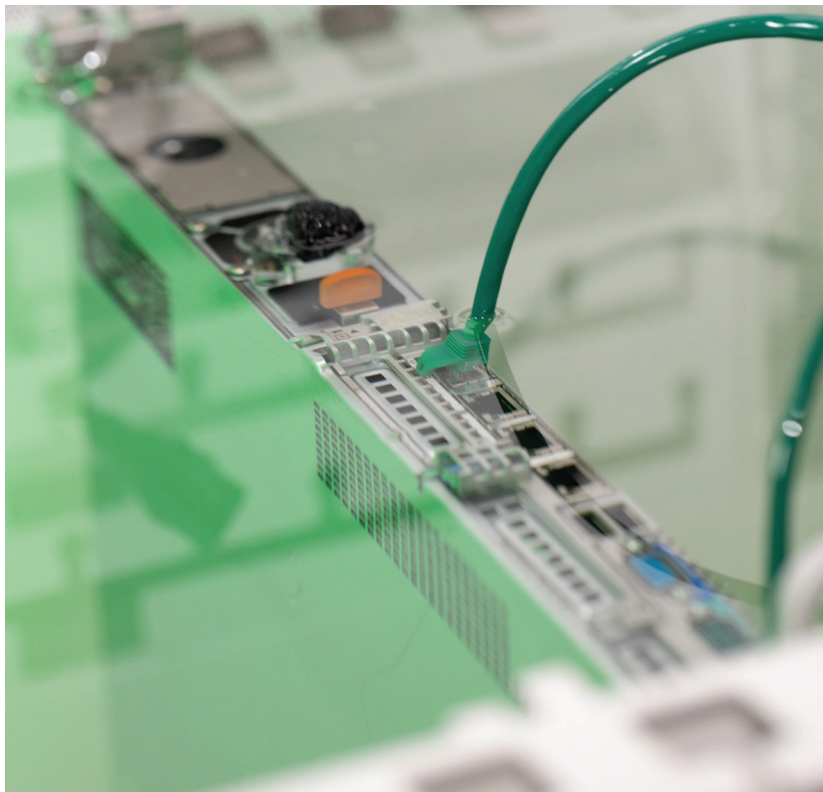

Single-Phase Immersion Cooling Up to 184 kW/Rack*

Servers are immersed in a liquid coolant for maximum heat removal.

* With chilled water



Compared to a data center of similar capacity, a single-phase, immersion-cooled GRC ICeraQ® installation can reduce carbon emissions by over 10K metric tons per year — a **21% improvement**

End of the Road For Air-Cooled Data Centers?

Comparing air-cooled to immersion-cooled data centers is a lot like comparing cars powered by internal combustion engines to those with electric motors. The first are great, and keep getting better, albeit more complex. Yet weighed against state-of-the-art electric cars they deliver lower performance and efficiency.

Not All Liquid Cooling Solutions

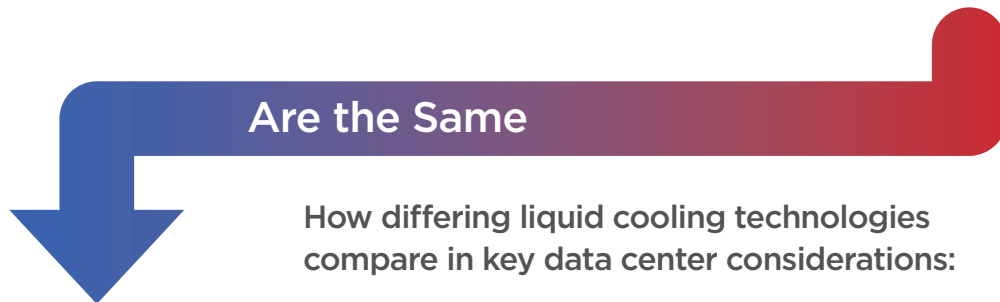

Key Considerations	RDHx	Liquid-to-Chip	2-Phase Immersion	Single Phase
Improved Energy Efficiency	●	●	●	●
High-Density Cooling Performance	●	●	●	●
Low Acquisition Cost	●	●	●	●
Sustainability	●	●	●	●
Minimal Complexity	●	●	●	●
Server Reliability	●	●	●	●
Simplified Operations & Maintenance Practices	●	●	●	●
Location Flexibility	●	●	●	●

Poor ● ● ● ● ● Excellent

Immersion Cooling

A Simpler and Smarter Solution:

As computing demands rose, liquid immersion cooling became a beacon of hope for I & O leaders looking to solve the heat dilemma in their data centers.



Here's How it Works:

Liquid immersion cooling moderates compute temperatures by completely immersing all heat-generating server components in a circulating, non-conductive liquid coolant. It offers the highest level of efficiency plus virtually unlimited capacity.



A single-phase immersion-cooled system from GRC can conserve precious resources by operating in a closed loop, no-water-loss system.

Why Immersion Is So Superior to Air

As data center operators came to realize in the early 2000s, there are limits to how effectively air can dissipate heat. This is why they turned to liquid coolants, which have significantly higher heat conductivity than air. **This is especially true for Earth-friendly, dielectric fluids like GRC's ElectroSafe[®], which can conduct 1,200X more heat than air.**

Rigorous Testing Bears This Out.

CPUs operating close to **100%** in **32 °C (89.6 °F)** air yielded an average core temperature of **85 °C (185 °F)**.

Yet when submerged in liquid coolant at **34 °C (93.2 °F)** the same CPUs yielded an average core temperature of **65 °C (149 °F)**.

Coolant & Core Temperature

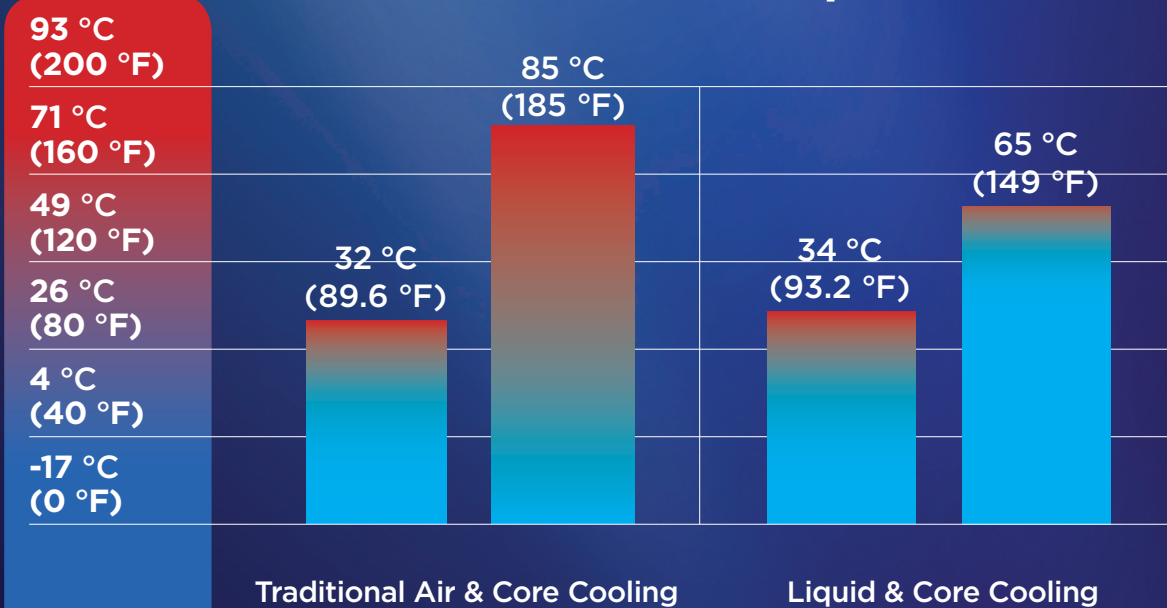

Types of Immersion Cooling:

Two-Phase vs. Single-Phase

Two-Phase Cooling

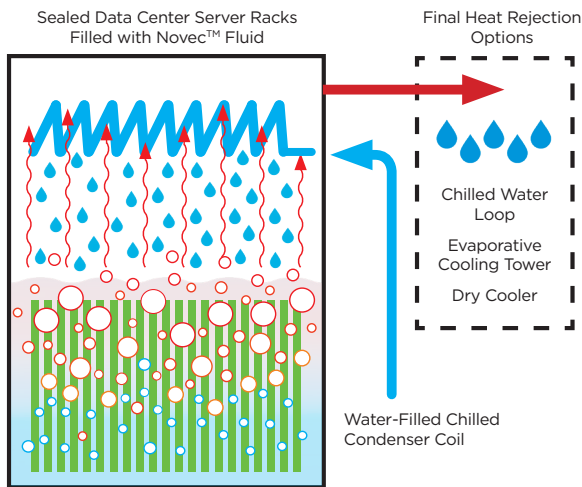

Novec Fluid Boils from Server Heat, Transforms from Liquid to Vapor and Passively Condenses Back to Liquid When It Contacts Water-Cooled Condenser Coils

While it boasts some impressive theoretical performance metrics, two-phase immersion cooling is very complex and far too expensive for today's data center cooling needs. Single-phase is considerably simpler, and has been proven cost-effective and highly reliable.

Single-Phase Cooling

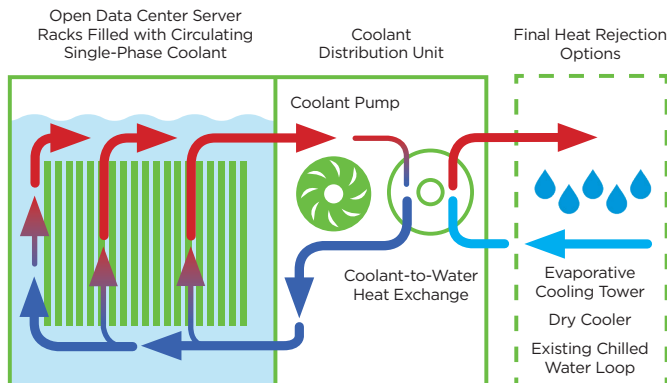

Heated Coolant Exits Top of Rack, Cycles Through the CDU and Returns to the Rack at a User-Specified Temperature.

Two-Phase Immersion Cooling Up to 250 kW/Rack

Cooling liquid is boiled off and the resulting vapor is condensed before being recirculated. Liquid to gas allows for higher heat removal but adds to system complexity.

- More complicated
- More expensive
- Less safe
- Costly coolants must be replenished about every two years

Single-Phase Immersion Cooling Up to 184 kW/Rack*

- More efficient
- Safer to use
- More cost-effective
- 15-year coolant life

Coolant remains in the liquid phase throughout the cooling cycle.

* With chilled water



Unlike two-phase immersion cooling formulations, GRC's ElectroSafe® fluid has no global warming potential (GWP), is non-toxic, non-volatile (no VOCs), and lasts the lifetime of a typical data center.

Single-Phase Immersion Cooling Keeps IT Cool

Over the years, data center hardware has run faster and hotter to keep up with computing demands. So, it's no surprise that once the benefits of fluid cooling were discovered it was moved ever-closer to the heat source. Finally, operators "took the plunge" and hardware was completely immersed in coolant.

Today, immersion cooling solutions have clearly proven themselves superior to their legacy air-based counterparts.

With single-phase immersion cooling systems like those developed by GRC, servers are placed in racks filled with a nontoxic, non-conductive coolant like our ElectroSafe. Heat from the servers is absorbed by the coolant and quickly removed from rack.

Refined through constant testing, our single-phase immersion cooling solutions can cool up to 100 kW/rack using warm-water systems, and nearly twice that with chilled-water systems.

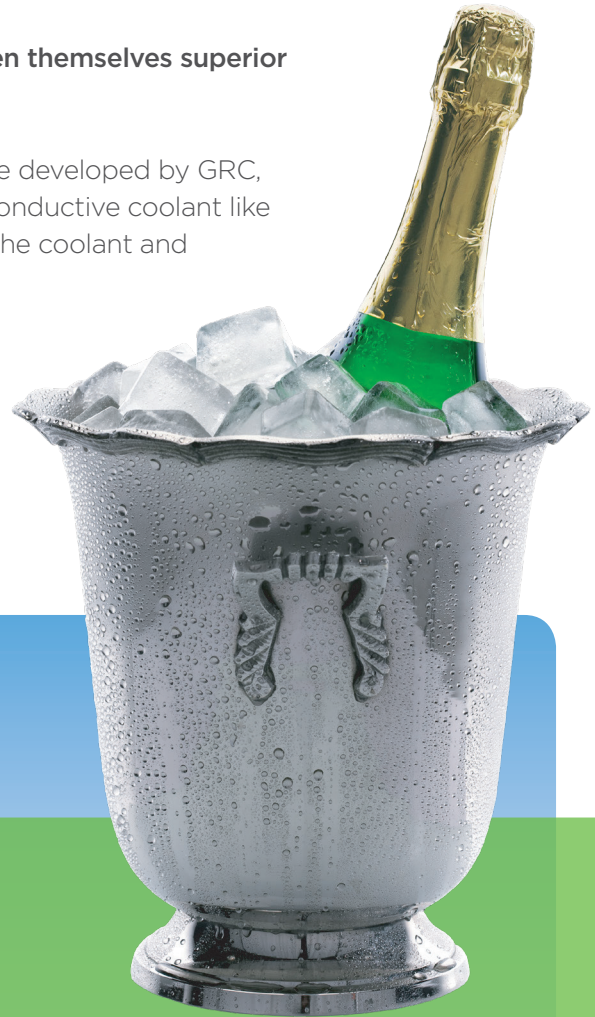

Single-Phase Immersion Cooling Features

- No CRACs or CRAHs
- No raised floors or chillers
- Only three moving parts
- Compatible with all major OEM servers
- 10-15% reduction in server power by removing fans
- Only 3% of compute load required for cooling
- No specially-treated water required

Cheers for Immersion!

Why is immersion cooling better than air?

Well, what's the best way to chill a bottle of Champagne? Placing it in the middle of a room and cranking up the A/C? Or putting it in ice water? The answer is obvious.

What Immersion Cooling

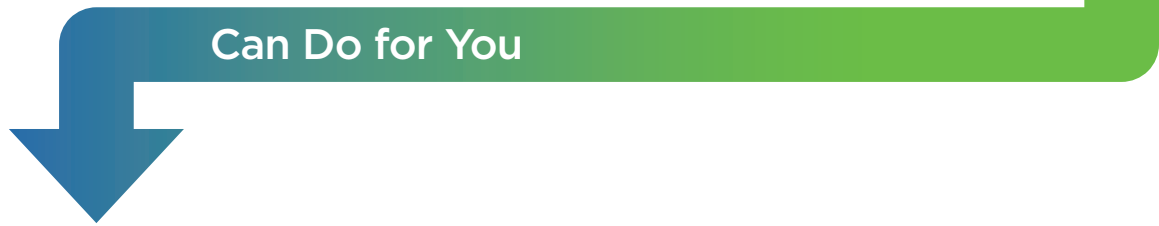

Single-phase immersion cooling can solve a wide range of data center challenges related to cooling, build & operating costs, deployment time, as well as space and power.



How Much Can You Save?

Our TCO Calculator illustrates how you can lower your total cost of ownership with immersion cooling.

[CALCULATE](#)



GRC's ICeraQ immersion cooling solutions can decrease compute footprint dramatically, supporting a 25% boost in computing performance without any increase in rack density or power consumption

Lower pPUE

Single-phase immersion cooling can deliver an pPUE of 1.03 or less — significantly less than free-air cooling. It works efficiently with input water temperatures < 32 °C (89 °F), even in extreme heat conditions where ambient temperatures approach 50 °C (122 °F). Plus, return water can be used for heat recapture to supplement incidental hot water and space heating needs.

Decrease CapEx & OpEx

Immersion cooling systems can be placed almost anywhere — in unimproved basements or spare rooms, parking lots, even outdoors in harsh environments, eliminating the need for larger data center fixtures such as raised floors, CRACs and CRAHs. Plus, lower power consumption means that investments in battery backup, generators, and power distribution can also be significantly reduced.

All things considered, GRC's immersion cooling solutions have shown to slash cooling energy costs up to 90%, and capital expenditure on new builds up to 50%. In the case of a retrofit, these savings can free up valuable power and water capacity to support more servers within the same data hall.

Significantly Shrink Compute Footprint & Infrastructure

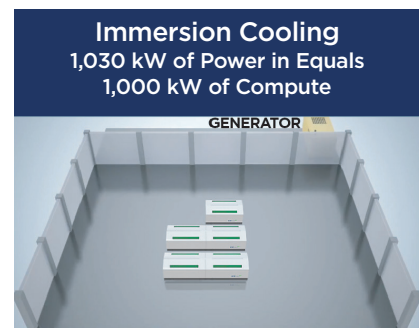
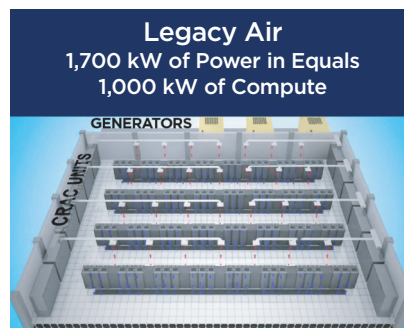

What Immersion Cooling

Can Do for You (continued)

✓ Single-phase immersion cooling can deliver a pPUE of <1.03

✓ Immersion cooling can reduce server power draw 10-20% or more

✓ Immersion cooling can cut cooling energy costs up to 90% and CapEx on new builds up to 50%

Reduce Server Energy Draw

Immersion cooling solutions like those offered by GRC can reduce server power draw by 10-20% or more. Removal of server fans, plus lower IT equipment operating temperatures, lessen power draw from the servers themselves.

Increase Reliability

Sealed off from the environment and stripped of any moving parts (vibrating fans), servers optimized or designed for immersion provide an exceptional level of reliability, and are easy to service. By eliminating CRACs, and CRAHs, immersion cooling also has fewer points of failure. That translates into higher levels of overall system reliability.

Solutions like GRC's ICEraQ® and ICEtank® systems even offer complete 2N redundancy. Plus, our ElectroSafe coolant provides extended catastrophic failure response time in the form of power-free cooling due to its high heat absorption capacity. Each 275-gallon server tank provides 13 kWh of ride-through time. Thus, a 12 kW rack would have over an hour of uptime.

Simplify Capacity Planning & Forecasting

Forecasting demand is very challenging with traditional data center layouts. Misjudgments can be expensive. In addition, I & O leaders must ensure they're using capital most efficiently, and not becoming bottlenecks for growth.

By contrast, GRC single-phase immersion cooling solutions give operators the flexibility to build out computing power and infrastructure in an almost linear fashion. With up to four racks per pump module, ramping up computing power can be done in much smaller increments than legacy cooling options.

Plus, our ICEraQ and containerized ICEtank systems are both fully integrated, prefabricated solutions providing economies without the constraint of scale. As a result, deployment times can be reduced to a few weeks versus the industry average of over nine months.

What Immersion Cooling

Can Do for You (continued)

Improve Operations and Maintenance

Because it has only three moving parts and needs no humidity controls, no air-flow engineering nor cold-aisle control, GRC's ICeraQ immersion cooling system can cut data center operating costs up to 50%.

Our horizontal rack design makes it easy to access and service the immersed equipment. Most traditional servers can easily be pulled out of the coolant and placed on support rails located on top of the racks. And remote monitoring simplifies maintenance, increases uptime and reduces labor through regular diagnostics, early fault detection, email alerts and more.

GRC immersion cooling eliminates frosty hot-cold aisle arrangements, and affords a silent work environment, too, which makes it easy to problem-solve right at the rack.

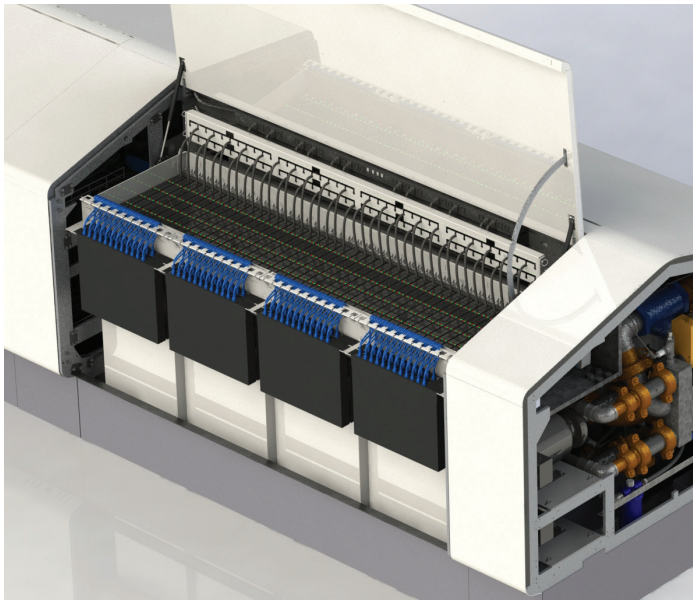

Cable Management

Clean, intelligent cable management makes life much easier — which is why GRC engineers our racks with a fully integrated cable management structure.



What Immersion Cooling

Can Do for You (Continued)

✓ Immersion cooling can cut data center operating costs by up to 50%

✓ Immersion cooling can reduce data center build time to a few weeks versus the industry average of over nine months



Delivering an pPUE of <1.03, GRC's immersion cooling systems can cut cooling energy costs by **up to 90%**



Immersion Cooling Myths

It Weighs a Lot

It doesn't. GRC's horizontal racks spread weight evenly for a floor loading that's often less than that of air-cooled racks and they can easily be placed on traditional raised floors.

It's Unsafe and Can Catch On Fire

Nope. ElectroSafe coolant is non-volatile, non-toxic and non-flammable (Rated 0-1-0).



Server Incompatibility

Not the case. GRC's immersion cooling solutions work with any OEM server.

Maintenance Is Different and Complex

Actually, with only three moving parts it's the epitome of simplicity. All server maintenance is done at a convenient waist height.

It's Messy

Hardly. Nearly all servicing of IT equipment takes place at the system, with coolant automatically returning to the rack upon removal.

What Immersion Cooling

Can Do for You (continued)



Significantly Support Your Organization's Sustainability Initiatives

By implementing immersion cooling, adopters can not only save money, but also operate more sustainably by reaching their carbon reduction goals. In particular, GRC customers have been able to:

- Win energy-efficiency grants and participate in green programs offered by local utilities and government agencies
- Attain better Carbon Disclosure Project (CDP) scores
- Lower Scope-1 emissions
- Lower carbon footprint up to 20%
- Decrease floorspace requirements
- Operate closed-loop, no-water-loss systems

Case Study – Zelendata Centar



- Serbia's First Green Data Center
- Repurposed, self-storage building
 - Tilt-up with a concrete floor
 - Not sealed
- Powered entirely by wind farm – day & night
- 100% battery storage to run during off times
- Utilizes a dry cooler
- Entire building energy usage is less than what the computers alone would have been without immersion cooling

Case Study – U.S. Air Force



- Containerized deployment
- 41% reduction in power consumed
- 93.1% pPUE reduction in cooling power from 1.45 to 1.037
- Power per rack unit increase of 314% due to ability to operate more compute in denser space
- Enabled smaller data center footprint requirements for the Air Force

So Many Challenges One Smart Cooling Solution

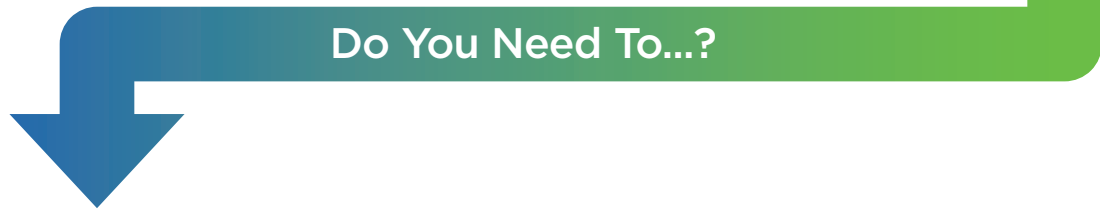

Do You Need To...?

Optimize Power to Expand Your Capacity or Avert Soaring Energy Costs Associated with High-Density Computing?

Immersion Cooling Can:

- Reduce compute power consumption up to a 30%
- Deliver a pPUE of <1.03
- Lessen compute load to 3% versus an industry average of 70%
- Cut data center energy bills in half

Gain Space to Expand Your Current Capacity?

Immersion Cooling Can:

- Facilitate expansion, cool up to 184 kW/rack, using a chilled-water system
- Allow you to add compute in any unimproved room, a parking lot, even outdoors
- Operate in the harshest environments

Avoid High Capital Expenditures for a New Data Center?

Immersion Cooling Can:

- Reduce build costs up to 50%, partly by avoiding traditional whitespace construction. This makes immersion the ultimate choice for “downtown” data center locations
- Defer costs by allowing incremental development — as low as 25 kW at a time
- Reduce compute cost up to \$300/server with servers designed for immersion (SDI)

Quickly Deploy Capacity for Edge Computing or Place Computing Power in Remote, Challenging Locales?

Immersion Cooling Can:

- Facilitate a data center in areas with extreme ambient heat, high humidity, and airborne particulates
- Deliver superior reliability and cost-effectiveness
- Get you up and running in as little as three months

Integrate High-Density Racks Into Your Operation?

Immersion Cooling Can:

- Effectively cool mixed racks within the same data center
- Allow you to add a dedicated on-premises HPC “pod” just for next-gen applications
- Cool up to 184 kW/rack, using a chilled water system
- **Compatible with ALL Leading Servers**





Here's What You Learned

- ✓ Offering a significant improvement in cooling performance, power consumption, sustainability and space utilization, single-phase immersion cooling solves a wide range of data center challenges.
- ✓ Legacy air cooling is structurally and physically incapable of keeping up with current data center demands.
- ✓ Competing cooling technologies — including liquid-to-chip and even two-phase immersion cooling — do not always meet key data center objectives.
- ✓ With the ability to cool up to 184 kW/rack, single-phase immersion cooling has the potential to cool even the densest racks for the foreseeable future.
- ✓ Single-phase immersion cooling solutions like ICEraQ from GRC are proven to help data centers like yours scale quickly and cost-effectively, lower costs up to 50% — across the board, increase server performance and reliability, plus maximize your power envelope.
- ✓ GRC is the pioneer of single-phase liquid immersion cooling, and has perfected the technology over the last decade plus.

Next-gen applications. Edge deployments. High-performance computing. Rising rack densities. Sustainability mandates — And more.

All told, the demands on today's data centers are considerable. And, the trends are inescapable — however a solution isn't. . .

...The Future is Here



Dive in

GRC is the World's Immersion Cooling Authority*

We offer both containerized and rack-based immersion cooling solutions to help our clients overcome location, density and budget dilemmas.



ICEraQ¹⁰ Micro-modular, rack-based, immersion cooling solutions for data centers

Cut the cost of building, running, and expanding your data center to achieve unprecedented cost, performance, and space efficiencies, while achieving sustainability goals.



ICETank Modular, immersion cooling solutions for data centers

Eliminate concerns about location or environment with our turnkey data center in a box. You provide the power, water and networking. We do the rest.

**Take the Next Step in Meeting Your Data Center's Demands —
Contact a GRC Expert!**

Call: +1.512.692.8003 Email: info@grcooling.com



+91 8806660084 **www.prasa-pl.com** **enquiry@prasa-pl.com**

11525 Stonehollow Dr. Suite A-135 • Austin, TX 78758 • United States • Phone +1.512.692.8003 • info@grcooling.com

©2021 GRC, Green Revolution Cooling, and The Immersion Cooling Authority are each registered trademarks of Green Revolution Cooling, Inc.