



VERTIV™



PRASA®

Liebert® Hipulse-E™

500kVA - 800kVA

AC Power for Business-Critical Continuity





We helped some of the largest names in the industry bring new capacity online faster and at a lower cost when search and social media increased demand for storage and computing.



We were the first to introduce an integrated enclosure system to distributed networks.



Our portfolio spans power, thermal and infrastructure management products, software and solutions.



Protecting your critical technologies takes more than just great software and equipment. It takes a level of experience that only comes from years of finding solutions when the industry needed them most. We were the first to protect mainframes with precision cooling systems.



And now as challenges and demands grow, we continue to find better ways to help you strengthen your most vital applications. Formerly the Network Power business of Vertiv, we've brought together the most trusted and experienced names in critical infrastructure.



Complemented by a network of nearly 250 service centers worldwide. It's a combination of experience and resources that allow us to better adapt to what's needed, anticipate what's next and continue to find solutions in ways other companies simply can't.



APPLICATIONS

- **Information Technology**
 - Data Centres
 - Servers (LAN, WAN, MAN, ERP, e-mail, web and others)
 - Networking
- **Telecommunication**
 - Mobile (2G, 2.5G, 3G and the likes)
 - Paging
 - Fixed (including WiLL)
- **Industrial Automation**
 - Process (including instrumentation)
 - Motion (digital drives & robotics)
- **Transport Automation**
 - Airport automation and flight booking
 - Others including railways & road transport automation & ticket booking
- **Banking, Insurance and Financial Services**
- **Software Development Houses / Software Technology Parks (STP)**
- **Building Automation**
 - Access Control
 - Security System
 - Fire Alarm System
 - Emergency Lighting
 - Other Critical Applications
- **Medical Diagnostics**
 - Magneto Resonant Imaging (MRI)
 - CT Scanning
 - CathLab
- **Satellite**
 - Uplinking
 - Earth Stations

Hi-Availability UPS

- The increased sophistication of critical & hyper critical applications in today's digital world and the enhanced dependence of your business on such applications have led Vertiv to design Liebert® Hipulse-E™ UPS to provide you high availability of quality power.
- Having extensively captured the customer needs and thoroughly mapped the same through 360° value analysis, Hipulse-E™ has been carefully designed to deliver high value: investment ratio.
- The proven performance & reliability of Liebert®'s Hipulse-E™ series, combined with customer delight and value added features have made Liebert® Hipulse-E™ the obvious choice across the globe for almost all the conceivable critical applications.



- From reliability to availability, from scalability to redundancy, from user-friendliness to maintainability, from parallelibility to connectivity, from investment protection to lower cost of ownership, whichever value you need, Liebert® Hipulse-E™ addresses them all efficiently and effectively, better than the best in the industry.
- Liebert® Hipulse-E™, as one of the prime members of our array of power quality solutions, is providing the 360° value

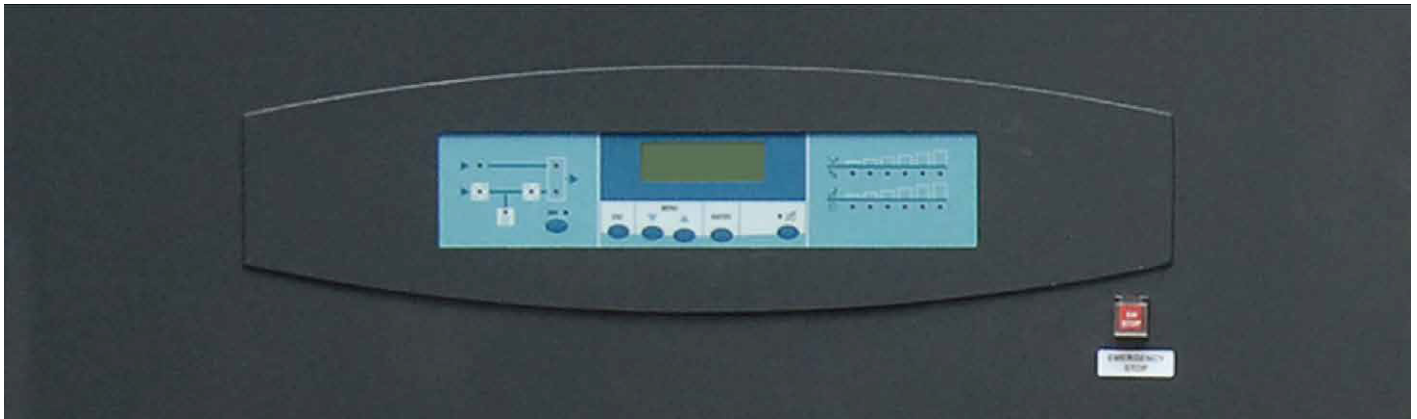

Top 10 Customer Values addressed by Liebert® Hipulse-E™ are:

- Hi-Availability of Quality Power by way of system redundancy and multi bus configuration using HiSync & HiSwitch
- Upstream Green Power achieved through low input current THD & high input power factor using 12-pulse with harmonic filter, depending on the requirement
- Reduced Cost of Ownership by way of improved input power factor (reducing electricity bill) and compact gross footprint (reducing active & passive occupied spaces)
- Ease & simplicity in Expendibility & Redundancy with the parallelability up to 6 modules with or without Main Static Switch (MSS)
- Investment Protection (for upstream semi-critical loads, UPS, battery and downstream critical loads) by way of reasonably wide input voltage & frequency tolerances (minimizing the events of battery discharging), optional temperature-compensated battery charging, back-feed protection, short-circuit-proof inverter.
- Maintainability by way of built-in maintenance bypass, optional wrap-around maintenance bypass, electrical interlocking system, redundant configuration (allowing you to maintain the redundant modules) and dual bus compatibility (enabling you to transfer the load to alternate bus)
- Serviceability by means of front accessibility of critical components, event logging with date & time stamping, hours-run indication and wide-angle (>180°) door-opening
- Flexibility in decision making though innumerable choices to pick from (e.g. type of battery, number of configurations, myriad combinations of 12-pulse with or without filter and array of internal & external power & communication options)
- User flexibility (choices of 5-language LCD, adjustable power walk-in, making myriad user-specified settings, having data through innumerable power communications alternatives etc.) and user friendliness (menu-driven LCD with detailed data reporting)
- Power Communications with the use of Relay Card, SNMP Web Card, ModBus / Jbus Card, MultiLink Software etc. Each one is designed to address the specific needs of each business function. For example, SNMP Web Card will be useful for your Network Manager, while the ModBus / Jbus Card will be more desirable to your Facility Manager.

Having understood & captured the customer needs across the world, the prime focus of the European Product Development Team of Liebert was to achieve a high level of value innovations to provide considerable value to you. Hipulse-E™ is a solution of that European initiative of Liebert, which offers you the best-in-class value.

Liebert® Hipulse-E™

500kVA - 800kVA

AC Power for Business-Critical Continuity



Value-Added Features

Having thoroughly understood & captured the present, latest & anticipated customer needs across the world, the Product Management Team of Liebert Hiross has come out with the following value-added features for your hyper critical applications.

Utility-Friendly & Generator-Friendly

Liebert® Hipulse-E™ with its 12-pulse rectifier version, considering in-built optional harmonic filter, is extremely utility-friendly. In this configuration, Hipulse E achieves <4-5% input current THD (Total Harmonic Distortion) and ≥ 0.90 input power factor (PF). The former one (the THD) ensures almost clean power in the upstream avoiding pollution and thus damage to the other semi-critical loads connected to the upstream power distribution bus. Moreover, it also ensures lower investments in cable costs (due to reduced cable size).

The later one (the PF) helps you maximising active power leading to saving in cost of ownership (in terms of lesser electricity bill) and also ensures reduced investment towards motor generator set (by way of minimising its sizing), making it generator-friendly. Overall, Hipulse-E™ is an Utility-Friendly & Generator-Friendly system employing this appropriate solution.

Horizontal Xpandability & Redundancy

Liebert® Hipulse-E™ is designed to parallel up to as high as six (6) UPS modules to achieve either capacity or redundancy. The system can grow (through horizontal xpandability) as your business grows or the system can provide you higher availability, as your business demands it. Achieving parallelibility up to six modules can be achieved with or without the centralized static switch & centralized controller. Thanks to Liebert's unmatched paralleling technique to provide you with both the alternatives aptly needed for large power UPS configurations.

Multi Bus Compatibility

Liebert® Hipulse-E™ has the feature of achieving multi bus configurations by the use of optional HiSync (to ensure synchronisation among the multi bus systems) and optional HiSwitch or Liebert HiSwitch2 (the static transfer switches).

This configuration will allow you to automatically transfer power (from one bus to the other, whenever the need arises). This gives you significant values to ensure high availability (Hi 9's) of quality power.

We have successfully executed multiple projects of 2-bus, 3-bus & 4-bus systems with HiSynch & HiSwitch. This is what made Hipulse the best-in -class High Availability UPS system. Liebert® Hipulse-E™ is an enhanced version of that Hipulse.

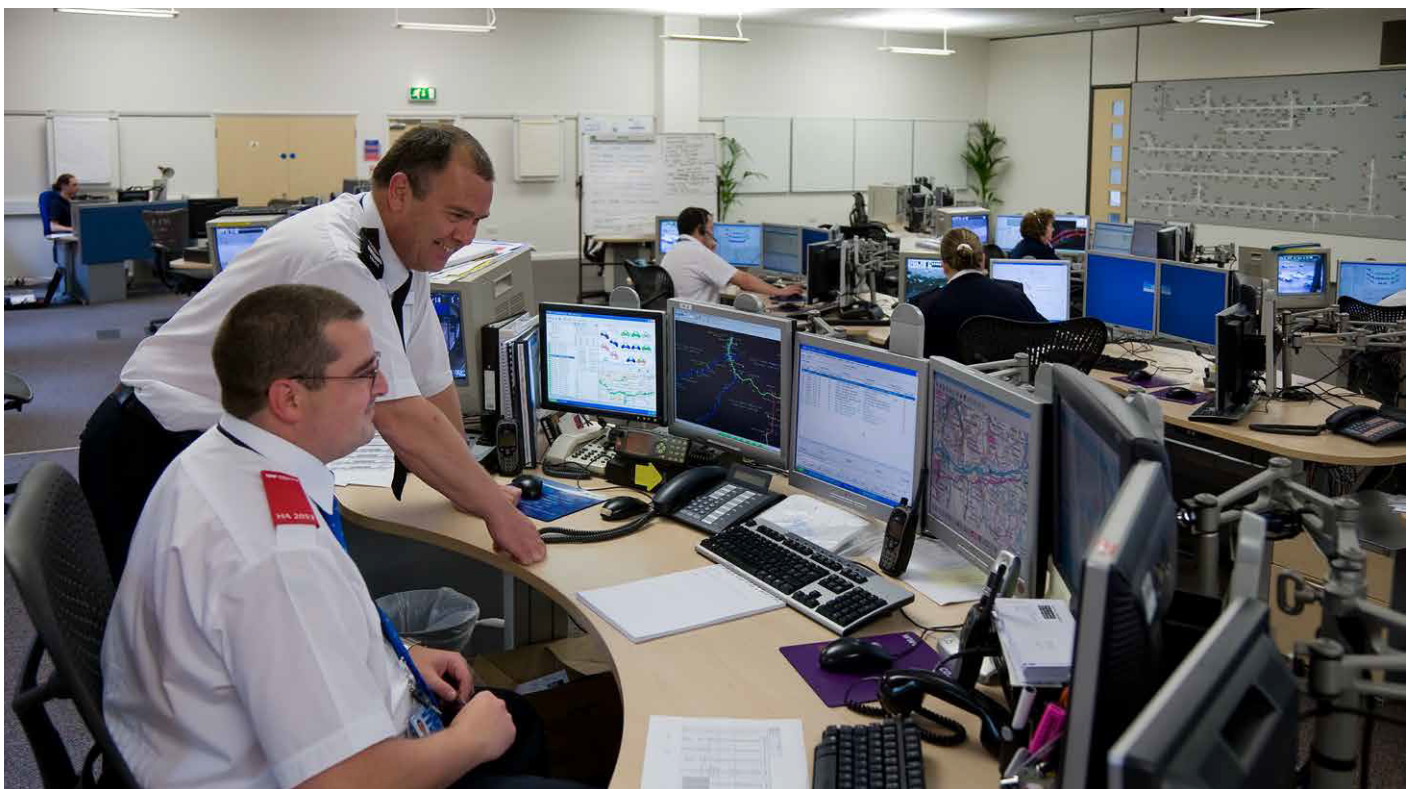

Flexi Power Walk-In

Liebert® Hipulse-E™ is designed to have flexible power walk-in (another unique feature) by way of adjusting the power walk-in from 5 seconds to 120 seconds. This gives you the opportunity to have optimized motor generator sizing (leading to reduced investment for you) and the user flexibility to have different walk-in time period for different paralleled UPS modules (offering user flexibility).

Temperature Compensated Battery Charging

Liebert® Hipulse-E™ allows the user to use optional temperature monitoring kit (to be connected to the battery bank) to monitor the temperature of the battery and thereby controlling the battery charging voltage. This helps you to protect the battery investment by way of protecting the battery health.

Compact Active & Passive Footprints

Liebert® Hipulse-E™ is designed to minimize both the active & passive footprints.

As you know, the active footprint is the physical, visible & actual floor space occupied by the cabinet. The passive one is invisible-but-implied space needed for the thermal management &/or accessing critical components like PCB's (Printed Circuit Boards),

Capacitors, Fans etc. Hipulse-E™ employs simple thermal management and front-access layouting objective.

The cool air is drawn from the front and the hot air is expelled out from the top. This is how Hipulse-E™ offers you a compact gross footprint, reducing your cost of ownership to the lowest possible level.

Hipulse-E™ can house anyone of the following remote power communication aids by means of the following optional hardware:

- Configurable Relay Card (to address the basic need of a user/maintenance persons)
- Open Comms Web Card (to address the needs of a network manager)
- ModBus / Jbus Card (to address the needs of a facility manager)



Other Remote Communications

Liebert® Hipulse-E™ also provides other communications alternatives through RS-232 & RS-485 ports and through HiroLink, IGMNet protocols. These provide you with the opportunity to integrate the communication system with our High Performance Air Conditioning (HPAC) systems. Other than utilizing RS-232 port for remote communication, it can also be used for local downloading of data for the service engineers, while the RS-485 port can be utilized to have remote communications of myriad applications.

Local Communications

Liebert® Hipulse-E™ provides excellent local communications by way of its Man-Machine Interface (MMI). The MMI of Hipulse-E uses some important push buttons (including “Emergency Power Off” :EPO with a transparent cover), LED-based MIMIC diagram and a LCD. While the MIMIC shows you the live power path, the back-lit LCD provides you with the requisite parameters of the unit in six (6) different languages (can be chosen from 8 different languages at the ordering stage) through user-friendly menu including event history with date & time stampings.

Customer Values are Mapped to Major Features of Liebert Hipulse E for ready References

	FEATURE-NEED VALUE MATRIX	PROTECTION			SYSTEM					COMMUNICATION							
Need Categories	Features	Back-Feed Protection	Dc Ground Fault Detection (option)	Short Circuit protected inverter	6-IGBT based PWM Invert	High Overload Handling Capability	Hot Standby Configuration	Parallelable up 6 (six) UPS Units without MSS	Parallelable up 6 (six) UPS Units	Dual Bus Compatibility	Event History on LCD	8-Language LCD (5: Standards, 3 optional)	Remote Alarm Monitor (RAM)	OpenComms Web Card	ModBus/Jbus/JBus Card	Programmable Relay Card	Hirolink
Customer Needs																	
Financial Needs	Reduced Investment																
	Lower Cost of Ownership																
Application & Business Needs	Investment Protection	●	●	●	●	●											
	Reliability				●												
	Hi Availability of Q Power					●	●	●	●	●							
	Scalability							●	●	●							
	Redundancy						●	●	●	●							
Application & Business Needs	Maintainability						●	●	●	●							
	Safety	●	●	●													
	Input Quality Power																
	Output Quality Power				●												
	User Friendliness				●						●	●	●	●	●	●	●
	User Flexibility						●	●	●	●			●	●	●	●	●
	Power Communication												●	●	●	●	●
Compactness																	
Intangible & Latent Needs	Serviceability	●									●	●	●	●	●	●	●
	Decision Making Flexibility					●	●	●	●	●							
	Customer Confidence																
	Simplicity & Aesthetics						●	●	●	●	●						

Liebert® Hipulse-E™

500kVA - 800kVA

AC Power for Business-Critical Continuity



	FEATURE-NEED MATRIX	INPUT				DC CIRCUIT & BATTERY				STATIC BYPASS					
Need Categories	Features	Input Current THDi <5% (optional with 12 p+Filter)	Input Power Factor >= 0.98 (optional with 12 p+Filter)	Input Voltage Range (323-477 V)	Input Frequency Range (47-63 Hz)	Input Frequency: 50 or 60 Hz	Adjustable Power Walk-In	DC Ripple Voltage <1%	Battery Test	Long Battery Discharge at Low Load	Battery Temperature Compensated Charging	Flexibility to use VRLA or Wet or NiCd Battery	Overloading Condition of 1000% for 10 msecs	Frequency Adjustment Range	Auto Retransferring Facility
		Customer Needs													
Financial Needs	Reduced Investment	●	●				●								
	Lower Cost of Ownership		●												
	Investment Protection	●		●	●			●	●	●	●				
Application & Business Needs	Reliability							●	●						
	Hi Availability of Q Power			●	●		●			●		●		●	
	Scalability														
	Redundancy														
Operational Needs	Maintainability														
	Safety														
	Input Quality Power	●	●												
	Output Quality Power														
	User Friendliness														
	User Flexibility					●	●			●				●	
	Power Communication														
Intangible & Latent Needs	Compactness														
	Serviceability														
	Decision Making Flexibility											●			
	Customer Confidence							●	●						
	Simplicity & Aesthetics														

	FEATURE-NEED MATRIX	OUTPUT				UNIT				SPECIAL FEATURE APPL					
Need Categories	Features	Output Voltage THDi <1%	Out Power Factor 0.7 (lag) to Unity	Output Voltage Regulation <1%	Output Frequency Regulation <1%	Output Frequency: 50 or 60 Hz	Small Gross Footprint	Door-Opening >180 degree	Top Venting (out) Fans	Front Access	IP-20 With Door-Opened Condition	Modern Styling	Castle Key Interlock Option	Input Galvanic Isolation Option	Top Cable Entry Option
		Customer Needs													
Financial Needs	Reduced Investment														
	Lower Cost of Ownership						●		●	●					
	Investment Protection	●	●	●	●	●							●	●	
Application & Business Needs	Reliability												●	●	
	Hi Availability of Q Power												●	●	
	Scalability														
	Redundancy														
Application & Business Needs	Maintainability	●													
	Safety							●			●		●		
	Input Quality Power														
	Output Quality Power	●	●	●	●	●									
	User Friendliness														
	User Flexibility														
	Power Communication														
Intangible & Latent Needs	Compactness														
	Serviceability							●		●					
	Decision Making Flexibility					●	●						●	●	●
	Customer Confidence							●				●	●	●	
	Simplicity & Aesthetics									●					

The system's advanced true-online, double conversion topology features a Micro-processor based controlled, 12 Pulse SCR based Rectifier and IGBT Inverter.

12 Pulse Rectifier

The rectifier provides up to 0.99 Input Power Factor (PF), up to 3% of Input Current Total Harmonic Distortion (THDi) with Optional configurations of Harmonic filters and the widest input voltage window and frequency tolerances.

PWM Based IGBT Inverter

Advanced inverter control technology provides the highest output power quality, ensuring very low output voltage THD and superior waveform to protect connected loads.

It operates under a wide variety of conditions, handling 100% non-linear loads with 3:1 crest factor, as well as 100% unbalanced loading.

The inverter control enables Hipulse-E™ to be suitable for the widest ranges of loads required by the market; delivering full active power rated kW up to 0.9 leading PF loads.

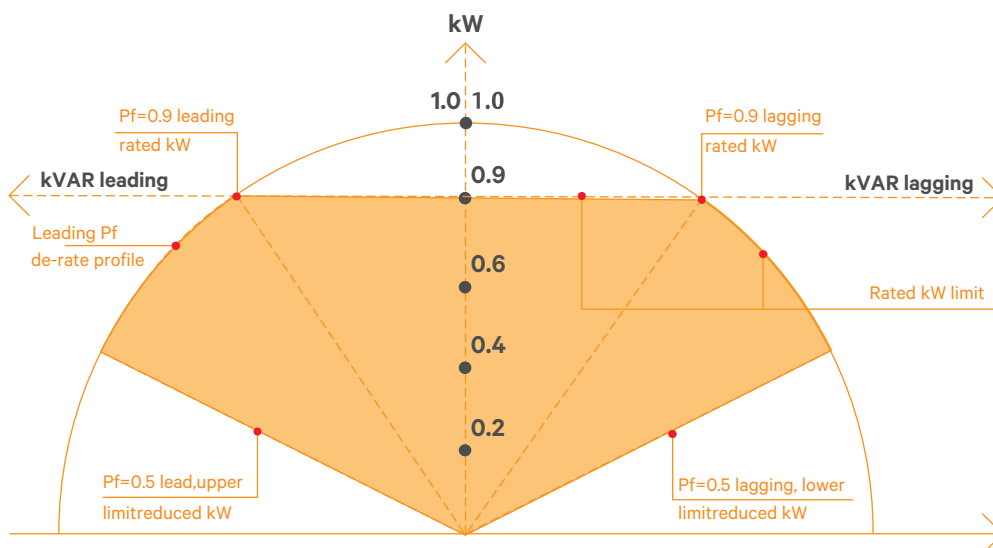

Value-added Power Options

Liebert® Hipulse-E™ offer you an array of value-added power options listed below:

External

- Battery Circuit Breaker (wall of cabinet mounted)
- Battery Cabinet
- Main Static Switch (MSS) for Centralised Static Bypass Switch
- Wrap-Around Maintenance Bypass Cabinet
- Top Cable Entry
- Input Isolation Transfer
- Remote Alarm Monitor (wall mounted)

Internal

- Paralleling Kit (for 1+5 modules)
- Input Harmonic Filter
- Common Battery Sharing Kit
- Fan Failure Alarm
- Power Communication Option
- IP Protection: IP21 - IP30 - IP31

Special Feature Applications (SFA's)*

- Dynamic System Expander (DSE)
- Multi-Bus (2-bus, 3-bus and 4-bus)

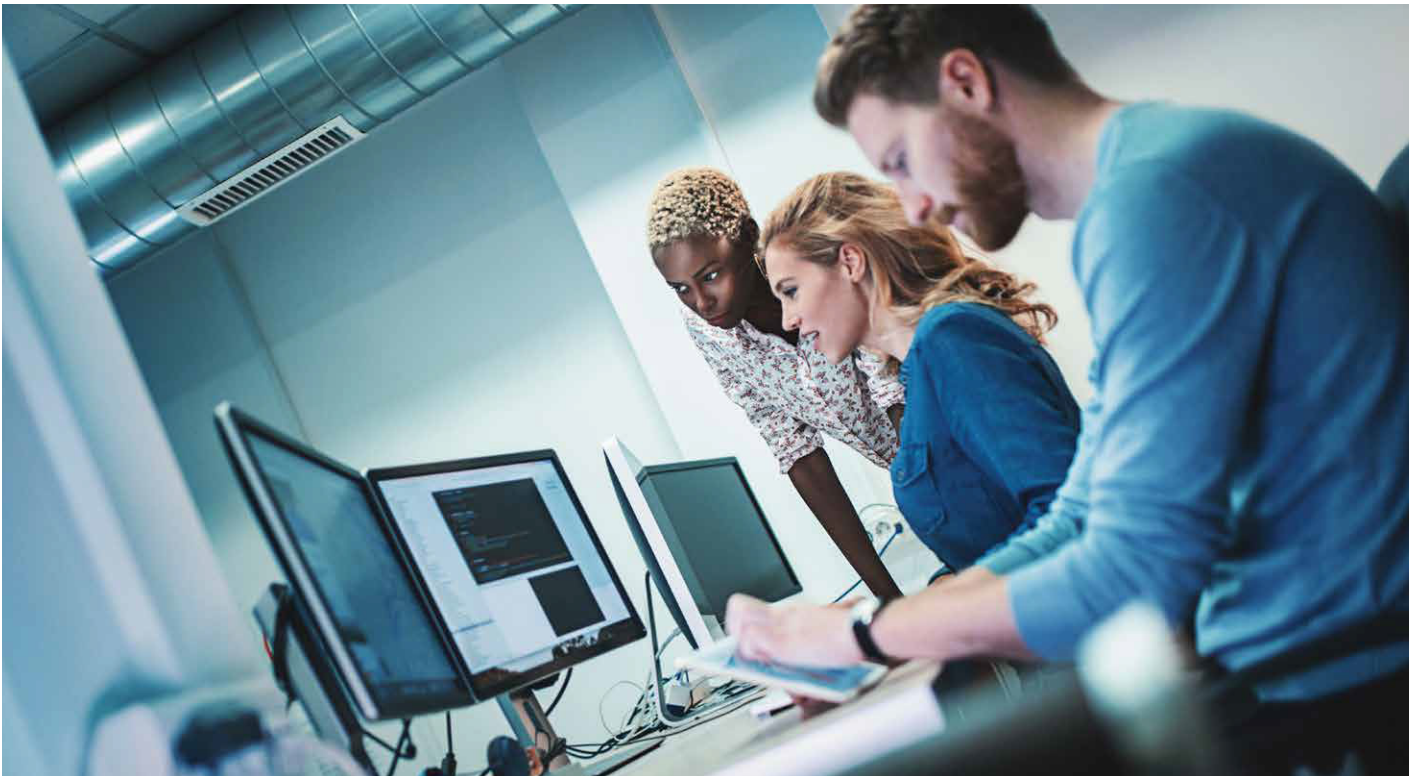

The Best Investment you can make in a UPS System: Reliability, Efficiency and Value in a compact package

How can I get the highest levels of Protection and Availability?

- Liebert® Hipulse-E™ gives you built-in reliability with power supply cards, highly efficient stratified cooling of critical components and cooling fans.
- Wider input voltage and frequency tolerances contribute to high power availability.
- Dual bus compatibility and system redundancy further enhance the availability of power.
- High overload protection handles 110% overload for 60 minutes, 125% for 10 minutes, and 150% for 1 minute.

How can I save on my electricity bill and investment costs?

- The improvement in input power factor of the Liebert® Hipulse-E™ can actually reduce your electricity usage.

- The unique ability of the Hipulse-E™ to adjust power walk-in from 2 seconds to 10 seconds selectable, along with reduced input current distortion and power factor correction, also enables you to save money by reducing backup generator sizing requirement.
- The unit's with transformer compact footprint requires less floor space, leaving you with more room for other equipment.
- Hipulse-E™ has features to Parallel up to six UPS an modules in redundant configuration for added reliability and serviceability, also it is compatible with Load Bus Synchronization (LBS).

How can I satisfy the requirements of the latest generation servers?

- Liebert® Hipulse-E™ is capable of driving wide ranges of loads, from 0.8 lagging to 0.9 leading without kW de-rating, this feature makes the UPS able to follow the latest IT industry trends, with more active power available for all kind of loads.

How can I protect also my upstream-connected devices?

- The Liebert® Hipulse-E™ provides the clean best level of upstream power with the lowest level of input current THDi in the industry with additional filters.
- This ensures that clean power flows upstream, avoiding damage to other loads connected to the upstream power distribution bus.

How can I protect and extend the life of my batteries?

- Liebert® Hipulse-E™ minimize transfers to batteries thanks to its wide input voltage tolerance.
- Temperature-compensated battery charging extends battery life.

How can I ensure the UPS will work under the most severe conditions?

- The wide input voltage window of +15/- 15% and a frequency tolerance of +/-10% provide high quality power, even when input parameters are below standard. This helps to minimize transfer to battery, reducing the charging and discharging cycles.
- Back-feed protection sensing ensures system integrity.
- Short-circuit-proof, IGBT Inverter provides highest output power quality.

How can I easily maintain my UPS?

- Liebert® Hipulse-E™ includes a built-in maintenance bypass, optional wraparound maintenance

bypass with IP 20 UPS enclosure protection -even with the front doors open.

- Redundant configuration allows you to utilize one module while the other is being serviced.
- Dual bus compatibility enables you to transfer the load to an alternate power source for maintenance activities.

How can I monitor and communicate with my UPS?

- To meet a variety of needs, the Hipulse-E™ can provide power simultaneous communications through a Relay Contact Card, OpenComms™ Web Card and MODbus J-Bus Card and MultiLink™ shutdown software.

How can I satisfy my particular installation needs?

- Flexibility is achieved through many choices including type of battery, number of single and multi-unit configurations, and an array of

internal and external power and communication options.

- Auto restart capability provides added availability.
- Ultra-quiet performance with noise levels below 75dB allows greater altitude in where to place the unit.
- Adjustable power walk-in, numerous user specified settings, a choice of power monitoring communications alternatives and user friendly control are all handled through the menu-driven LCD control panel with detailed data reporting.
- Vertiv is recognized to be a great solution provider. Please contact your local Vertiv India office

How can I check my UPS status?

- The Hipulse-E™ features easy access for service thanks to front accessibility of critical components, self-diagnostics and various monitoring options.
- Large and user-friendly LCD display provides operating information on front panel of UPS Module.

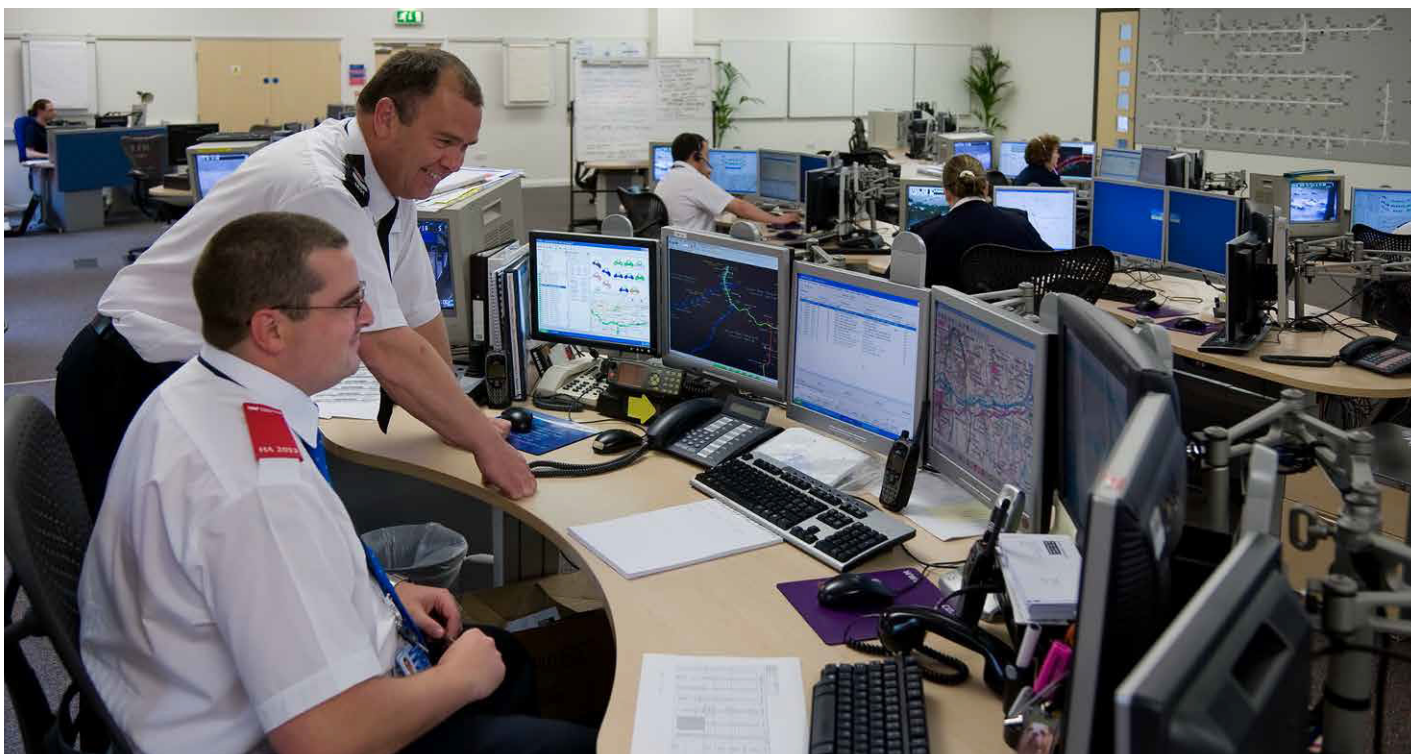

Hipulse-E™ can be scaled up to as high as 6 modules using any of the following configurations to achieve either scalability or redundancy of desired percentage

- 1+N configuration without any kind of centralised static switch
- Some more configurations are explained further in this brochure
- For other configurations, please contact our nearest sales office / representative

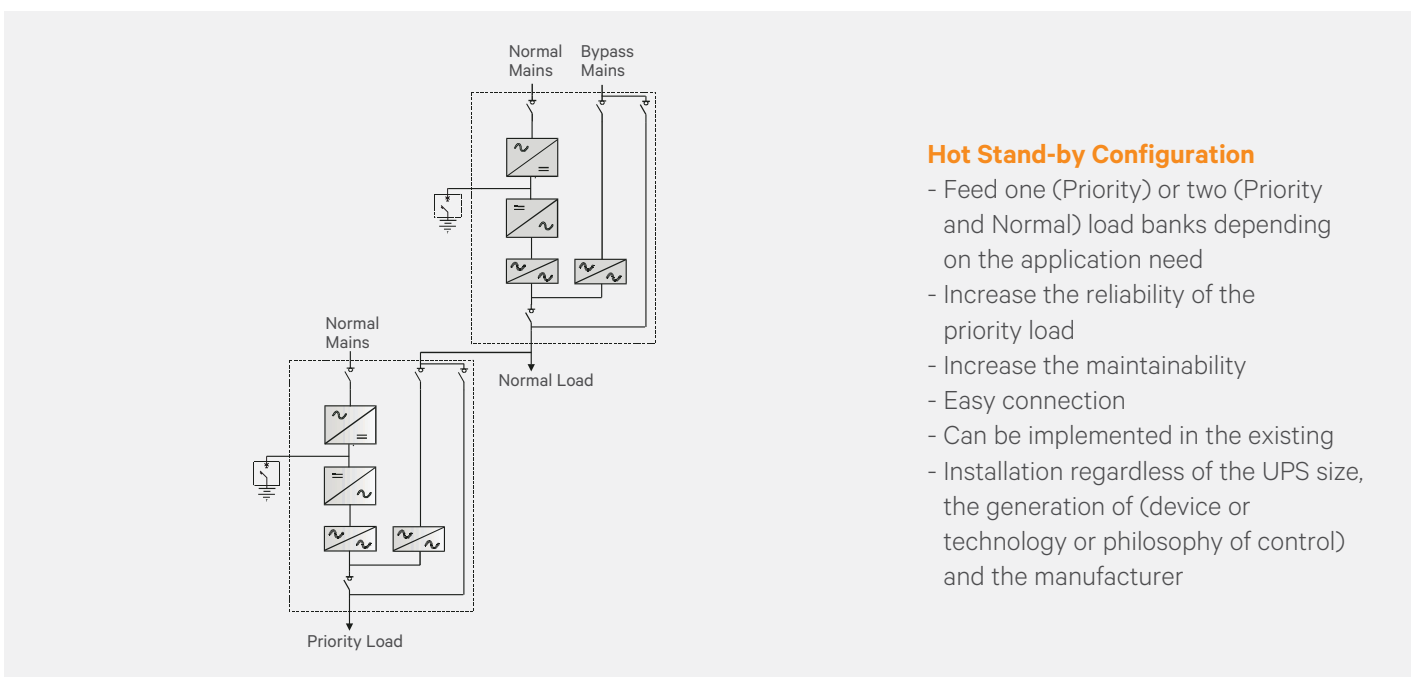
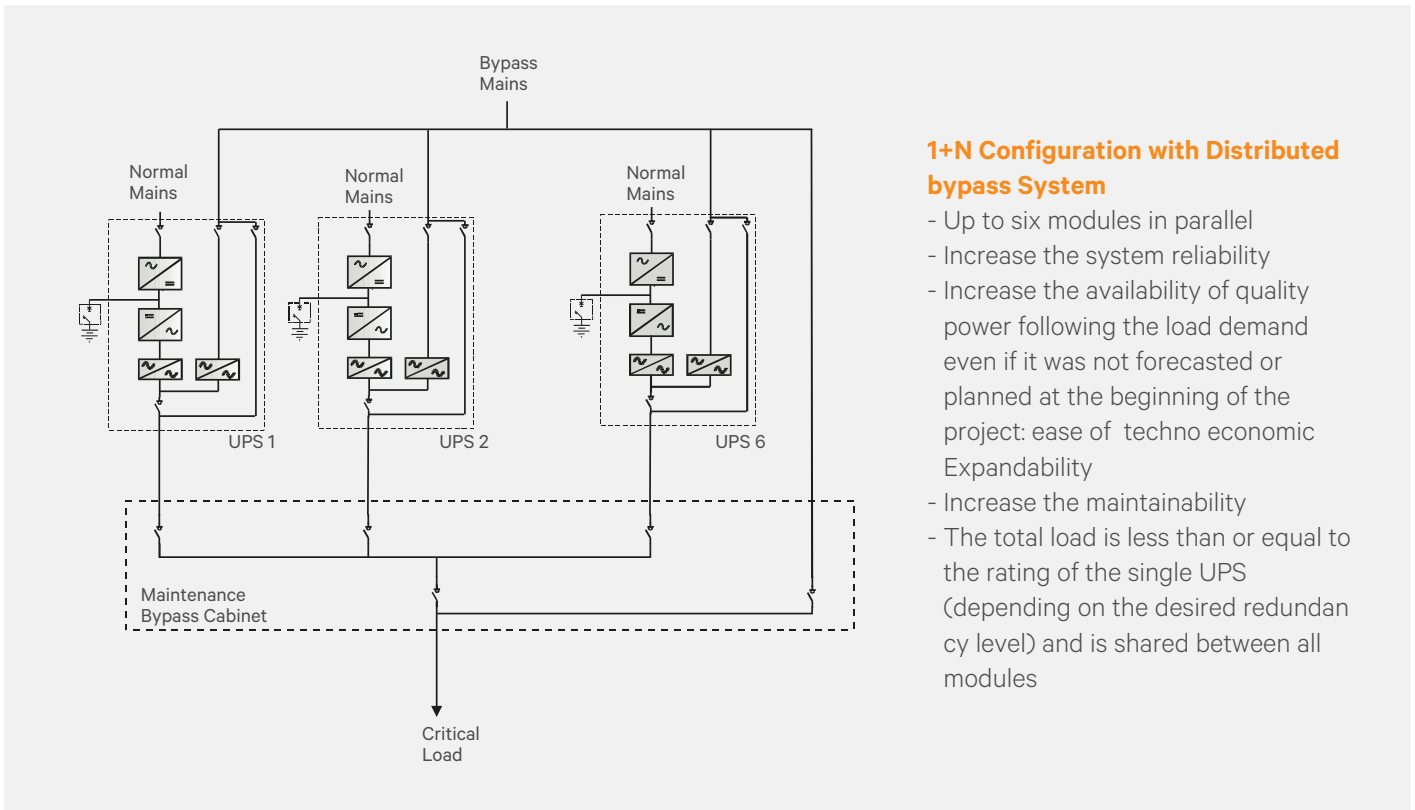

Dual Bus System with Liebert® LTS, STS2 or Hiswitch2

- Provide supply to the loads from two independent power sources
- The two may be different in terms of power rating and redundancy
- The two BUS outputs are in synchronism between them
- Automatic transfer of the load between the two sources in case of fault using Liebert LTS
- Increase dramatically the maintainability and reliability

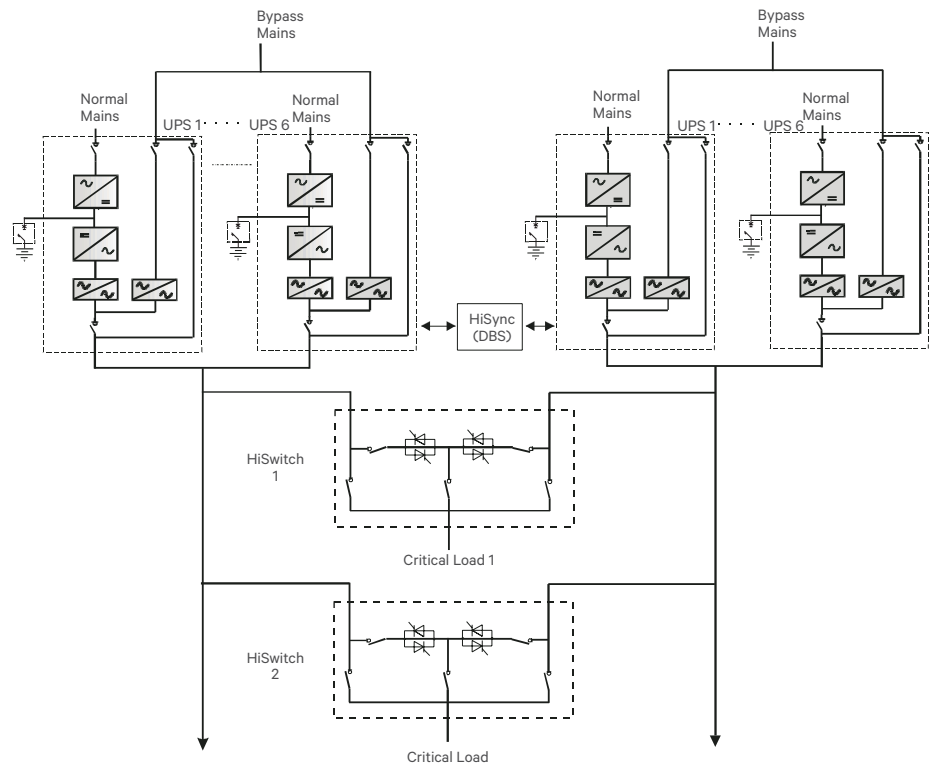

Multimodule Configuration WITH Centralised Bypass Called Main Static Switch (MSS)

- Up to six Modules in parallel
- Increase the system reliability
- Increase the power availability up to the MSS Capacity
- Increase the maintainability
- The Total load is less than or equal to the rating of the single UPS (depending on the desired redundancy level). The load is shared between all modules.

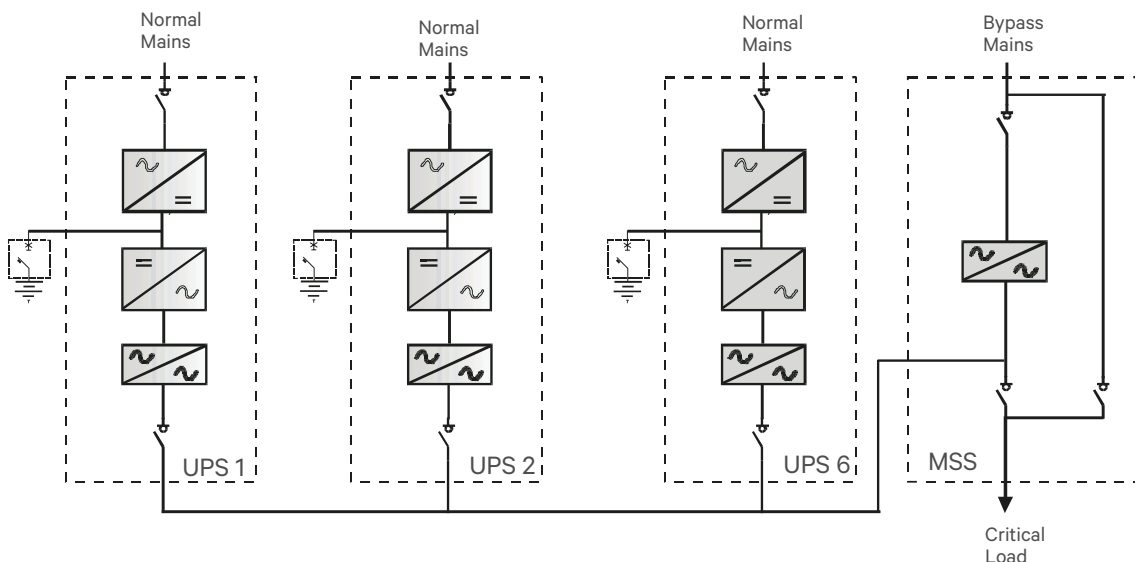

General Features

Nominal Rating	kVA	500	600	800
Input Parameters				
Input Voltage to Rectifier	Vac	380/400/415* (400V: nominal) 3-phase, 3-wire		
Input Voltage to Rectifier	Vac	380/400/415* (400V: nominal) 3-phase +N, 4-wire		
Permissible Input voltage Range	Vac	323 to 457		
Input Frequency	Hz	50 or 60		
Permissible Input Frequency Range	Hz	47 or 63		
Input THDi at nominal voltage at full load	%	<3% with 12-pulse + Filter®		
Input Power Factor at nominal voltage		>=0.99% with 12-pulse + Filter®		
Flexi Power Walk-In	Second	5 to 120 (selectable)		
Battery & DC Parameters				
Battery Type		VRLA (Valve Regulated lead Acid) or Wet or Ni-Cd		
Nominal Battery Bus	Vdc	480	396	480
		(Float Voltage: 540V)	(Float Voltage: 446V)	(Float Voltage: 540V)
End-Cell Voltage	Vdc/Cell	Selection from 1.65 to 1.90 (for VRLA/Wet Cells)		
DC ripple voltage in float & Const V Ch. mode	%	<1 (RMS value)		
Temperature compensated Battery Charging		Optional		
Output Parameters				
Inverter Type		IGBT-based Sine-Sine PWM Controlled		
Output Power	KW	450	540	720
Output Voltage	Vac	380/400/415* (400V: nominal) 3-phase, 4-w		
Output Voltage Regulation	%	+/- 0.5 (3 phase RMS average)		
Output Frequency	Hz	50 or 60		
Output Frequency Regulation	%	+/- 0.05		
Output Voltage THD at nominal voltage	%	1 (typ), 2% (max)		
Capacity to handle High Crest Factor Load		3:1 (compliant with IEC 62040-3)		
Capacity to handle Step Load	%	0-100 or 100-0		
Transient Recovery	M seconds	10 (recovery to 95% of the voltage level)		
Capability to handle Leading PF Load		Up to 0.7**		
Voltage Displacement	°el	120° +/- 1° el (with 100% unbalanced load)		
Overload Conditions	%FL	110 for 60 minutes / 125 for 10 minutes / 150 for 1 minutes		
System Parameters				
UPS Efficiency (without any power option)	%	Up to 93.5 (depends on rating & operating condition)		
Physical Parameters & Standards				
Width (applicable to 12 pulse version)***	mm	2460	3200	4410
Depth mm		1000		
Height mm		1900		
Weight 12p (approx.)	kg	4200	4500	5050
Color		RAL 7035		
Front door Opening (for better Serviceability)		More than 180°		
Degree of Protection for UPS Enclosure		IP 20 even with front door in opened condition		
Standards & Conformities		IEC 62040-3, IEC 62040-2, IEC 62040-1-1, CE Mark: EN 62040-1-1, EN 50091-2, EN 62040-3, EN 60950, EN 60529 and VFI 111		
Environmental Parameters				
Storage Temperature	°C	-25 to 70 (UPS) & -20 to 30 (Battery)		
Operating Temperature Range	°C	0 to 40 (UPS) & 20 +/-5 (Battery)		
Relative Humidity	%	0 to 95 (non condensing)		
Maximum Altitude above MSL (Mean Sea Level)	m	1000 (as per IEC 62040/3)		

* 4-5% more power output for 415V input & output; ** with suitable derating; ***with OR without input harmonic filter

@ Combination of Active + Passive Filters

While specifying the parameters here, it is assumed that, extremes of all the conditions do not apply simultaneously.

© 2004 Liebert Corporation. All rights reserved throughout the world. Specifications subject to change without notice. All names referred to are trademarks or registered trademarks of their respective owners. This UPS system will give more active power at lower ambient Temperature



VERTIV™



PRASA®

Prasa Infocom & Power Solutions Pvt. Ltd.

🌐 www.prasa-pl.com ✉ enquiry@prasa-pl.com

VertivCo.com | E-mail : marketing.india@vertivco.com | Toll free : 1-800-2096070

Vertiv Energy Private Limited | Plot C-20, Rd No.19, Wagle Ind Estate, Thane (W), 400604. India

© 2017 Vertiv Co. All rights reserved.